

Series 4, integrated rangehood, 53 cm, Silver metallic DHL555BAU

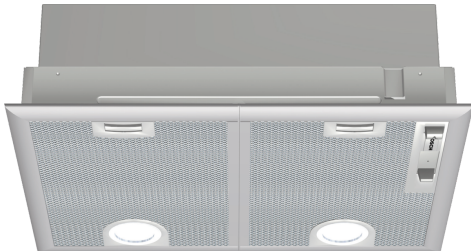

DHZ7402 Installation kit for canopy
 DHZ7305 Standard odor filter

The integrated rangehood: offers a sleek and seamless design in the kitchen with fully integrated installation.

- **Especially silent:** maximum rangehood performance with minimal noise.
- **Grease filtration level:** filters out over 85% of the grease from kitchen air
- **LED lighting:** for perfect, energy-efficient illumination of the cooktop.
- **Intensive speed setting:** removes strong kitchen odours especially quickly and effectively.
- **With exhaust, the air is cleaned by a grease filter and then ducted to the outside which ensures optimal kitchen air quality.**

Typology: Built-in/Built-under
 Length electrical supply cord: 130.0 cm
 Min. required niche size for installation (HxWxD): 255mm x 500.0mm x 350mm mm
 Minimum distance above an electric cooktop: 600 mm
 Minimum distance above a gas cooktop: 650 mm
 Net weight: 7.4 kg
 Type of control: mechanical
 Number of power settings: 3-stages + intensive setting
 Max. air extraction: 420 m³/h
 Boost position output recirculating: 430.0 m³/h
 Max. air recirculation: 320 m³/h
 Boost position air extraction: 650 m³/h
 Number of lights: 2
 Noise level: 59 dB(A) re 1 pW
 Diameter of air outlet: 120 / 150 mm
 Grease filter material: Washable aluminium
 EAN code: 4242002527093
 Connection rating: 206 W
 Voltage: 220-240 V
 Frequency: 50 Hz
 Plug type: AU plug
 Installation typology: Built-in



Series 4, integrated rangehood, 53 cm, Silver metallic DHL555BAU

The integrated rangehood: offers a sleek and seamless design in the kitchen with fully integrated installation.

- Accessory required for recirculation mode: Standard recirculation kit

Design

- Appliance colour: Steel body, metallic finish

Power and Mode of Operation

- 3 power settings plus intensive setting
- Extraction rate according to EN 61591 \varnothing 15 cm: max. Normal use 420 m³/h. Intensive 650 m³/h
- Suitable for ducted or re-circulated extraction
- Sliding switch control for power and light
- Powerful twin motor
- Noise min./max. Normal Level: 41/59 dB

Comfort & Convenience

- Dishwasher safe metal grease filters
- On / Off indicator lights
- 2 x LED spot 2,15W (low volt)
- Power rating: 206 W

Dimensions (HxWxD)

- Dimensions recirculating (HxWxD): 255-255 x 530 x 380 mm
- Dimensions exhaust air (HxWxD): 255-255 x 530 x 380 mm
- 120 or 150 mm tube connection diameter
- Electrical cable length 1.3 m

**Series 4, integrated rangehood, 53 cm, Silver metallic
DHL555BAU**

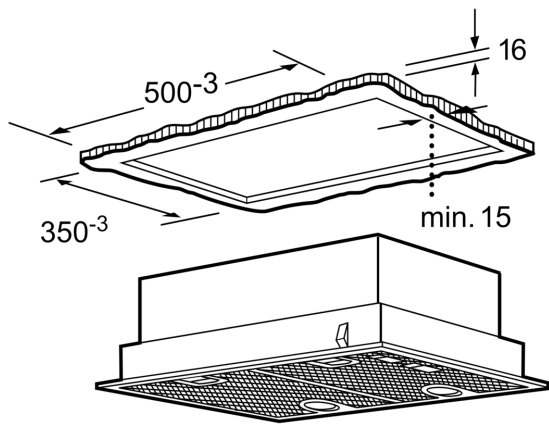

measurements in mm

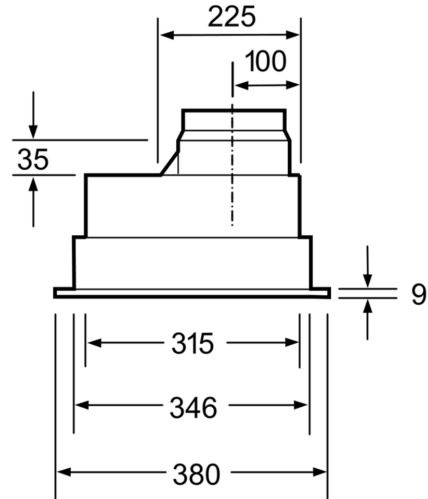

measurements in mm

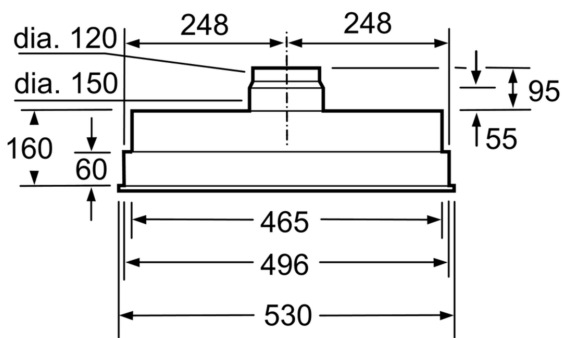

measurements in mm

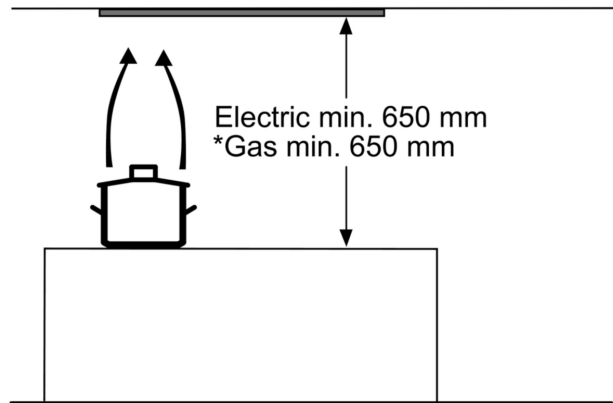

* from upper edge of pan support

measurements in mm